



- VME 6U Board
- Based on VME64x Architecture
- Available in three variants - Commercial, Air-Cooled, Conduction-Cooled
- Vibration, Shock resistant
- Complies with IEEE 1101.2 mechanical specifications
- Programmable Interrupter: 7 Levels
- Dimensions- 233.35 x 160mm
- Isolation and non-isolation options available
- Input Voltage: TTL and Open Collector
- Optional - Two Asynchronous Channels of RS-232 or RS-422 or 1 each of RS-232/422 Serial Interfaces
- Programmable Baud Rates up to 115.2 k/Bauds
- Driver and high-level API libraries for Windows XP, Linux, RT-Linux, LynxOS 4.0 and VxWorks 5.5

OVERVIEW

The AT family of 6U VME Discrete I/O boards are designed to provide users with a high degree of reliability and flexibility to meet input-output requirements. The AT-VME-DIO boards provide an economical method for isolation and interfacing of I/O signals to the VME bus. Optical-relays, which are built-in, are provided for each I/O channel. These eliminate the expenses incurred due to the usage of external relay panels. They are ideally suited for stringent military and airborne applications.

On-board relays isolate all the inputs, outputs and the VMEbus from each other against all sorts of transients emanating from ground loops etc. The AT-VME-DIO provides 32 channels of isolated inputs and 32 channels of isolated outputs. The voltage levels supported are TTL and Open Collector voltages. Also available on the board are 2 serial asynchronous RS-422 channels. These have a programmable baud rate up to 115.2 k/Bauds.

Hardware

The AT-VME-DIO boards meet the VME 64x standard and are available in a 6U form factor. The boards are available in three variants - Commercial, Air-Cooled and Conduction-Cooled versions. It is designed to work in units meeting MIL-STD-461C for EMI/EMC and MIL-STD-810F for airborne applications. All the components used are of MIL grade quality as per airborne application requirements in the conduction-cooled version. Front panel and Rear I/O connectivity options are provided for commercial and air-cooled boards. Conduction-cooled boards are available with Rear I/O connectivity only.

AT-VME-DIO-64

VME Bus Compatible Discrete I/O Board

PRODUCT SPECIFICATIONS

Discrete I/O

- 32 Channels of Opto-Isolated Inputs
- 32 Channels of Opto-Isolated Outputs
- One optocoupler / channel
- Minimum isolation of 500 V
- Non-isolated VME boards also available
- Voltage level: TTL Logic, Open Collector 0-48V
- Rear I/O Connectivity on P2

Discrete I/O

- 2 RS-232 or 2 RS-422 or 1 each of RS-232/422 Asynchronous Channels
- Programmable standard baud rates up to 115.2 k/Bauds

Mechanical Formats

- Commercial/Development version- Standard VME
- Air-cooled version- As per ANSI/VITA 1-1994
- Conduction-cooled version- As per IEEE 1101.2

Dimensions

- Dimensions- 233mm x 160mm
- IEEE 1101.2 single-slot board with 0.8-inch centers

VME Interface

- VME 64x, 6U form factor
- A24/D16 interface

Power

- Consumption: 2.25 watts
- 5V @ 450mA

Interrupts

- Programmable interrupter 7 levels
- Samples & compares periodically the status of the I/O channels
- For every change, VME bus interrupt is asserted

Software Support

- Driver and high-level API libraries for Windows XP, Linux, RT-Linux, LynxOS 4.0 and VxWorks 5.5
- Virtual Instrument Panels for interactive control of Discrete I/O and UART features
- Self-test and built-in test features provided

Diagnostics

- Built-In-Test (BIT) of all on-board TTL chips
- Wrap around loops to verify correct board operation

Environmental

- Wrap around loops to verify correct board operation

	Air-Cooled	Conduction-Cooled
Operating	0°C to + 60°C	-40°C to + 85°C

Ruggedization

- Series 'C': Commercial/Development Version
- Series 'A': Air-Cooled Version
- Series 'M': Military / Conduction-Cooled Version

Warranty

- 1 year limited warranty

ORDERING INFORMATION

Hardware Selection

AT-VME-2-2-DIO-Channels-Ruggedization

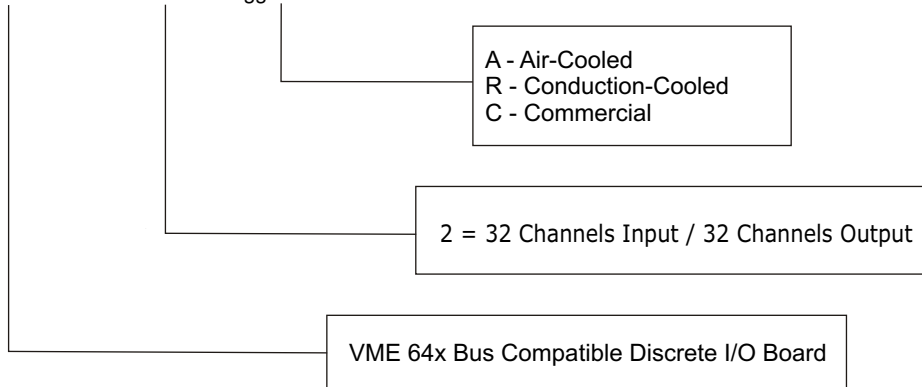

- Contact sales for support for other Operating Systems
- Contact sales for configuration of front and rear I/O configuration
- Contact sales for environmental options



ADTEC Electronics Inc.
144 Continente Ave , Suite #130
Brentwood, CA 94513, USA.
Ph : (408) 420 0646
www.adtecelectronics.com

Distributor/Reseller