

- XMC - x1 Lane PCIe, 2.5Gbps / PMC - PCI bus 32-bit, 33MHz
- IPC429 - Next generation 429 core
- Improved architecture to enhance performance
- 16 Transmit Channels, 16 Receive Channels
- Configurable for High Speed/Low Speed
- Low host CPU load through FIFOs
- Upto 256 Label memory for each Receive channel.
- 128 Word Tx and Rx FIFOs for each Transmit and Receive Channel.
- Programmable interrupts
- Asynchronous and Synchronous Messaging
- Programmable Refresh rates of 20ms min to 200ms min
- Rear P16 or Rear P14 or Front I/O available
- IRIG-B Time Code Input (Digital)
- 48-bit, microsecond time tagging
- Label Selective Trigger for Capture/Filtering and SDI filtering
- Optional discrete I/O and IRIG-B
- Optional Disconnect of Arinc429 transmit channels through PhotoMos Relays
- Available in two variants -Air Cooled, Conduction Cooled
- Driver & High-level API for Windows XP, Windows 7 and Linux.
- LabVIEW drivers available optionally

OVERVIEW

The AT-XMC/PMC-429 card enable electronic systems to interface with commercial and military avionics data buses. They provide extensive functionality and are used to communicate with, simulate, test, and monitor ARINC429 equipment and systems. This high-density high-performance card is suitable for applications ranging from test equipment to rugged deployable systems. A wide selection of models is available: XMC and PMC, front and rear panel I/O, various ARINC channel counts and capabilities. They all include avionics discrete, timers, IRIG Synchronization/ generation. All modes may be used in either conduction or air cooled systems.

The card is designed to transmit and receive messages up to 32 channels. Upto 16 channels for Receive (Rx) and 16 channels Transmit (Tx) mode. Each channel is software configurable for high or low speed (12.5k or 100k bits per second) and ARINC429 protocol requirements. To provide I/O and processing expansion capabilities, I/O are available on either rear user I/O connectors or front panel VHDCI Connectors. An onboard IRIG-B time encoder and decoder allow users to accurately synchronize single or multiple modules to a common time source. The ARINC data word can be decoded and sorted based on the Label and SDI bits and stored in FIFOs. The card is integrated with powerful software that reduces development time.

Software

The AT-XMC/PMC-A429 software includes Drivers & APIs. The product comes with a powerful set of library functions to access the entire ARINC 429 functionality. The drivers are designed in a modular fashion consisting of component functions and application functions. The user's test program can be developed with few calls to the driver by using the set of application functions provided. Driver and high-level API libraries for Windows XP, Windows 7 and Linux are available. LabVIEW drivers available optionally.

AT-XMC/PMC-429

Multichannel High Performance Arinc429 Mezzanine Card

PRODUCT SPECIFICATIONS

Bus Interface

- XMC - x1 lane PCIe, 2.5Gbps (PCIe base specification 1.0a) or PMC - 32-bit, 33/66 MHz (PCI 2.2)

ARINC429 Interface

- Supports up to 32 ARINC429 channels
 - > 16 Transmit Channels
 - > 16 Receive Channels
- 128 Word deep FIFO on each channel
- Programmable Interrupts
- Built-in Fault Detection Circuitry
- Set parity per channel (odd/even/data)
- Sync output on all or selected messages
- Handles periodic and transfer protocols
- Message filters and schedules
- Data rates: 12.5 kbps/50 Kbps in Low Speed and 100 kbps in High Speed
- Standard input levels: ±6.5 to ±13 VDC
- Filtering: Label and/ or SDI
- Parity: Odd, even or none
- Error reporting: Parity
- Output levels: ±10 VDC

Others

- Optional Eight Discrete Inputs and Outputs
- Optional IRIG Digital IN
- Optional Disconnect of Arinc429 transmit channels through PhotoMos Relays
- 48-bit hardware time-tag (1µs resolution)

Discrete I/O

- Two TTL Discrete Inputs & Discrete Outputs only in XMC mode
- Optional Six TTL Discrete Inputs & six Discrete Outputs in PMC mode

IO Configurations

- IO available on both Front Panel 68 pin VHDCI Connector and Rear Connectors (P14 - PMC or P16 - XMC)
- Standard configuration is P16 rear panel I/O

Software Support

- Driver and high-level API libraries for Windows XP, Windows 7 & Linux
- Sample applications will be provided
- LabVIEW drivers available optionally

Physical

- Standard Singlewide Mezzanine Card form factor conforming to IEEE 1386.1 (74 mm x 149 mm)
- Conduction Cooled XMC/PMC Card without Bezel

Environmental

	Air-Cooled	Conduction-Cooled
Operating temperature	0° C to +60° C	-40° C to +85° C

Power

- Primary Supply +5V, +3.3V, +12V and -12V from PMC Connectors when configured as a PMC Card, +3.3V and all other voltages internally derived
- Primary Supply +3.3V, +12V, and -12V from XMC Connectors when configured as XMC Card, all other voltages internally derived

Warranty

- 1 year limited warranty

ORDERING INFORMATION

Hardware Selection

AT-XMC/PMC-429- Controller-Channels-DIO-IRIG-Ruggedization

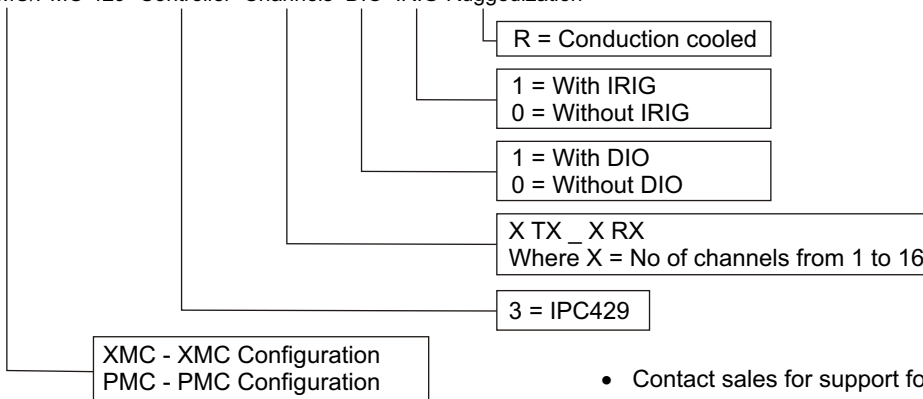

- Contact sales for support for other Operating Systems
- Contact sales for configuration of front and rear I/O configuration
- Contact sales for environmental options



ADTEC Electronics Inc.
 144 Continente Ave , Suite #130
 Brentwood, CA 94513, USA.
 Ph : (408) 420 0646
 www.adtecelectronics.com

Distributor/Reseller